

NOTES

1. These drawings shall be read in conjunction with the Preliminary Design Report, CP1901_3FM-COWI-SBR-SP-RP-S-00002
2. Structural steelwork Grade 355+W to IS EN 10025 typically.
3. Typical active travel details applicable for both lifting and approach spans. Some modification will be required for access to Pier 4, to be determined at detailed design stage.

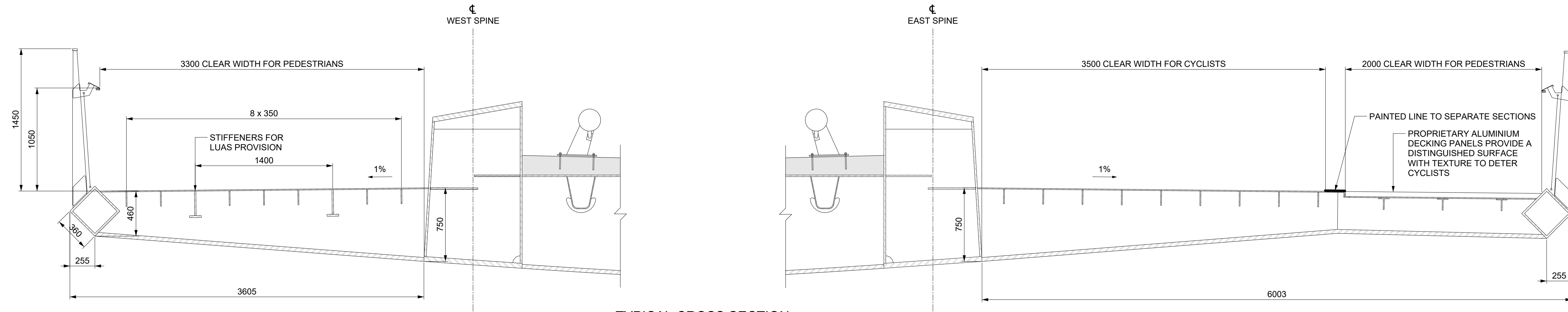

TYPICAL CROSS SECTION
LIFTING SPAN SHOWN, APPROACH SPAN SIMILAR

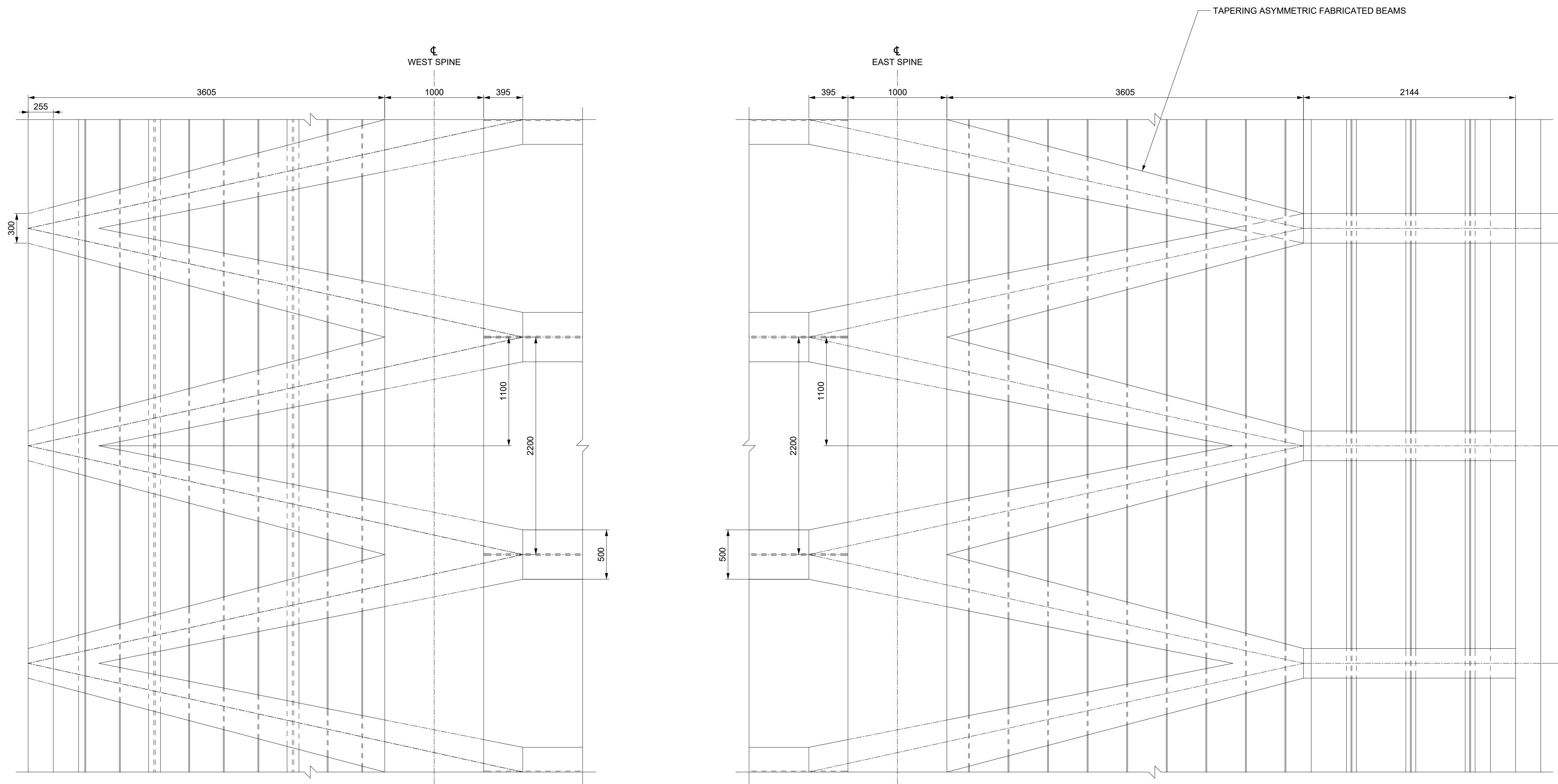

TYPICAL SOFFIT VIEW
LIFTING SPAN SHOWN, APPROACH SPAN SIMILAR

2	Revised for Planning Comments	OLSS	28/06/24
1	Revised for Stage Approval	OLSS	19/04/24
0	First Issue	OLSS	28/06/23
rev	amendments	check	date

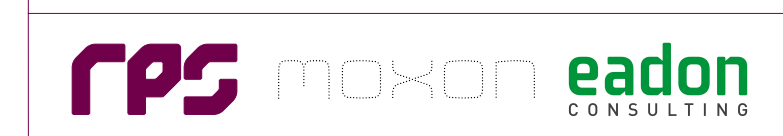

Title
**SPAR Bridge
Active Travel Provision**

Project Number	Sheet Size	Drawing Scale
CP1901_3FM	A1	1:25

Drawing Number
COWI-SBR-SP-DR-S-100-00300

Drawn By	Status	Revision
C. Fleming	S4	2

Checked By	Approved By	Date
O. Stross	O. Stross	28/06/2024