

SECTION B-B

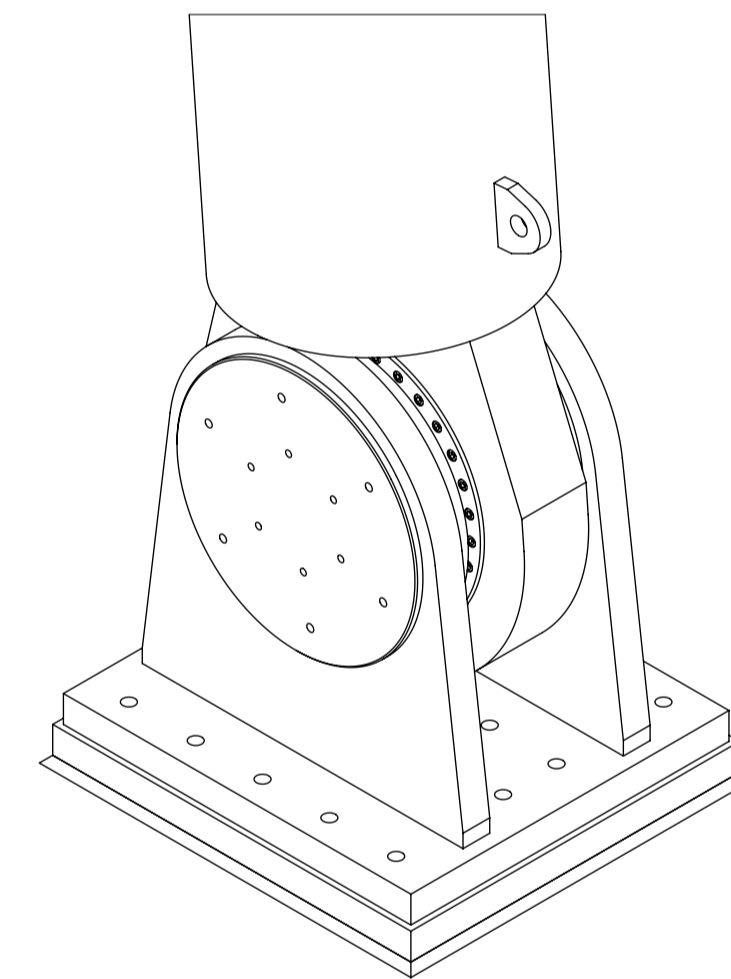
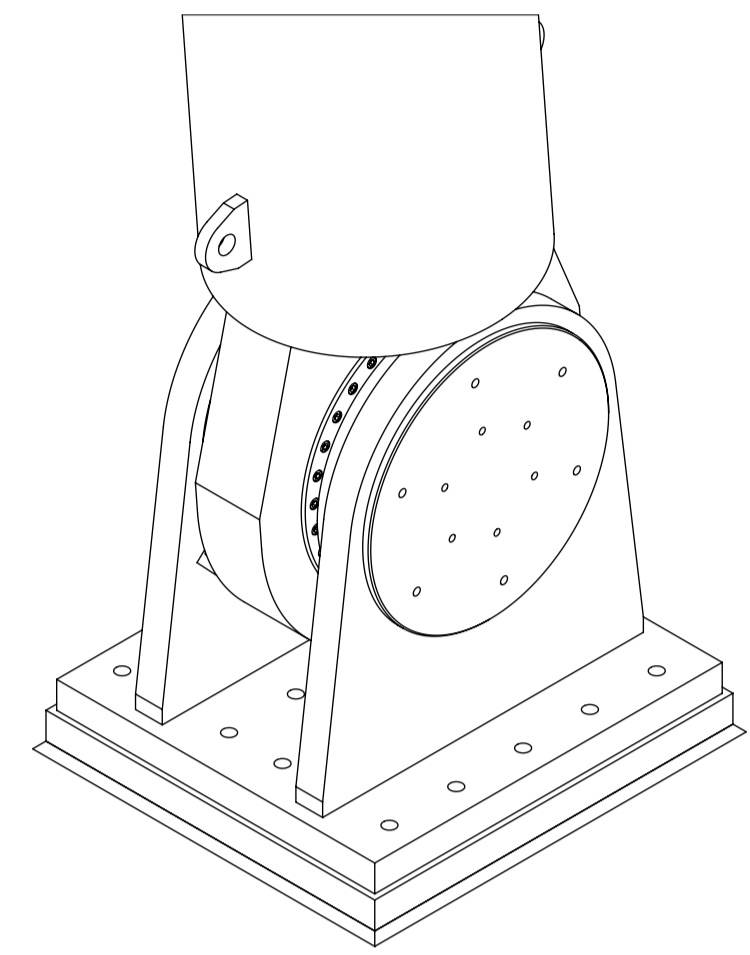

NOTES

1. OUTLINE DESIGN FOR PLANNING. FURTHER DESIGN DEVELOPMENT REQUIRED.
2. DIMENSIONS ARE INDICATIVE AND REQUIRE FURTHER VERIFICATION.
3. NOT FOR MANUFACTURE.

rev	amendments	check	date



Title
SPAR Bridge
Lower Cylinder Mount

Project Number	Sheet Size	Drawing Scale
CP1901_3FM	A1	1:20

Drawing Number
EADON-SBR-SP-DR-M-100-00053

Drawn By	Status	Revision
M. Thorogood	S4	1

Checked By	Approved By	Date
C. Fleming	O. Stross	14/07/2023